



Heavy Duty

REELING SYSTEMS

Contents

Introduction to Systems	2 - 3
Level Winding Reels	4 - 5
Monospiral Reels	6 - 7
Cable Selection	8 - 9
Cable Data	9
Cable Use	10 - 11
Cable Installation	12 - 13
Cable Anchoring	14 - 15
Cable Guides	15
Reeling Functions (Types)	16
Electronic Motor Drives	16 - 17

Heavy Duty Reeling Solutions

Why a Workbook? Motor reels are designed for specific applications. To help us design your reel, use this book as a set of working sheets. This workbook is designed to help both of us evaluate your needs and to give us a foundation on which to build an accurate, professional proposal. This workbook asks questions; it suggests typical solutions; and it provides check lists which will assist you in reviewing the items and issues required for a good solution to your need.

If you use reels regularly, you know the importance of providing complete cable and application data to the manufacturer. Use this workbook to walk you through the process. At any time, contact our office or your local representative for assistance.

If you are new to reels, please allow us to emphasize how important your input is to us. We base our work on the data you supply. We must rely on your cable selection and your description of how that cable is to be used.

Our goal is to see that your valuable cables are handled in the safest, most reliable way - Gleason calls it "Cable Management"!

Important Considerations

CABLE LENGTH - Length of cable required to cover machine travel, mounting height of reel, safety wraps and hook-up.

CABLE TENSION - The amount of allowable pulling force on any cable depends upon cable size and construction.

CABLE BENDING - Bending tolerance is stated in "Cable diameter multiplied by a factor". See "Cable Bending Data".

CABLE INSTALLATION - Care must be taken in handling during installation.

CABLE ANCHORING - At termination, cable must be treated carefully to ensure good connections, solid anchoring and proper bending. Serviceability must be fully considered as well.

CABLE TWISTING - Cable will twist from manufacturing causes. Twist should be removed for long life and good performance.

REEL DRIVES - A variety of drive methods are available with no specific drive being "best" for all applications. Your specific needs and experience, combined with Gleason's expertise will be the best guide to drive selection.

"TWO-WAY PAYOUT"

You can cut the required cable length in half simply by plugging the cable in at the *center* of travel. This results in the cable being used "twice" for each complete run (TT). For example, a machine travelling 100 ft. only needs 50 ft. of cable. The illustration below shows this effect.

Note that the reel performs *exactly the same operation each side of center*. It is the "reorienting" of the reel relative to the anchor point that matters.

T = Half Travel The reel provides "T," or one complete "reel-out/ reel-in" cycle, each side of center.

TT = Total Travel or Machine Travel (T + T). TT is two (2) complete cycles of the reel.

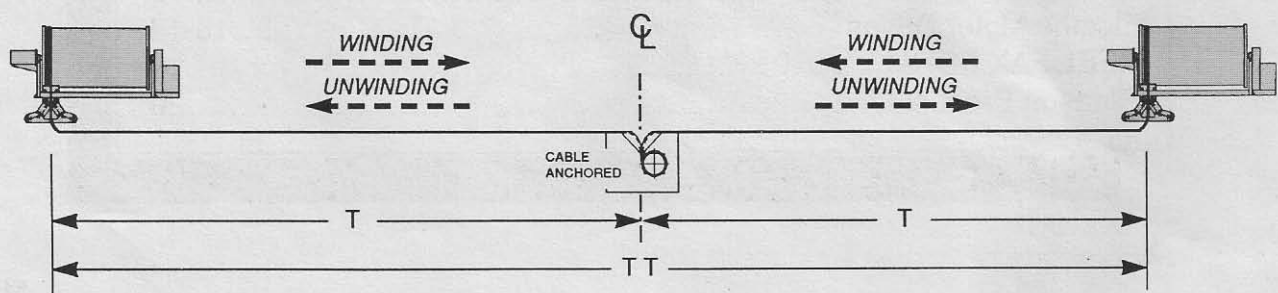

Reeling Basics



Electric cable reels are comprised of three (3) major assemblies, plus accessories: SPOOLS to store the cable; SLIP RINGS to transfer current from the fixed cable to the rotating spool, and; DRIVES to power the spool. Accessories include cable guides, cable anchors, limit switches, heaters, etc.

1. Spools

Spools hold the cable and must be designed to allow repeated "unwinding and rewinding" of the cable. The best spool will have total control of the cable, regardless of conditions. The single layer levelwind (lateral) spool and the monospiral (vertical spool provide such cable control - the cable has no alternative but to wind in the assigned space. The random wrap spool will its own space and is, therefore, less reliable. An additional advantage to single (mono) wrapping is that cable is fully exposed for heat dissipation and derating considerations. For these reasons, random wrap reels are generally used for short cable lengths (<250 ft) or where space makes it difficult to fit a better spool.

Spring reels are typically random wrap for reasons of space and economy.

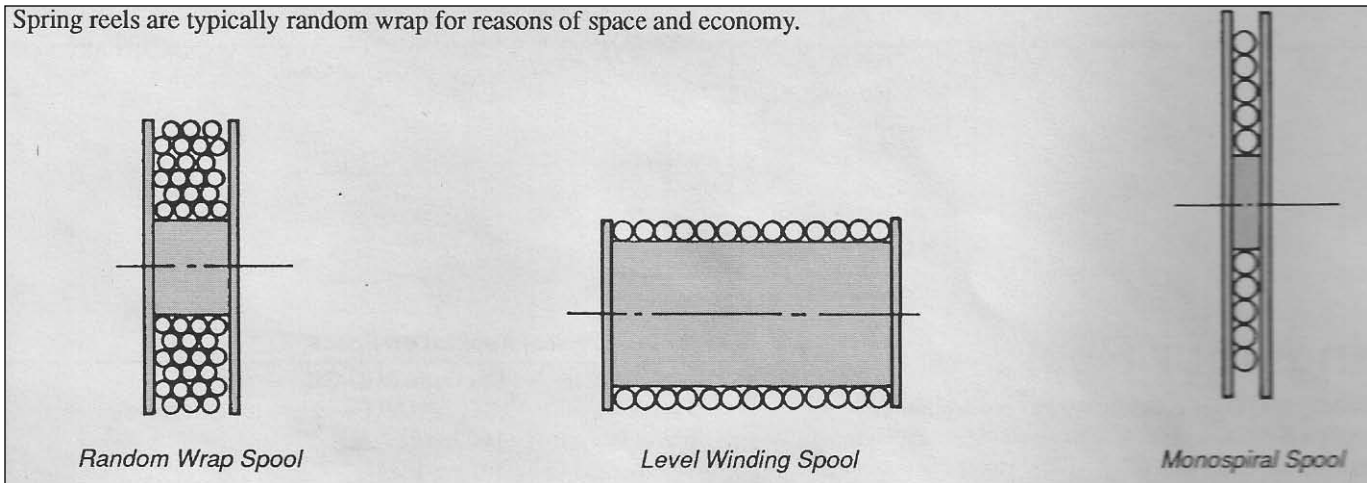

2. Drives for Reeling

Drive methods are best if kept simple, whenever possible.

A. MECHANICAL SPRINGS are the most economical for short and intermittent cable use. Springs are generally not recommended for high duty cycle applications or long cable lengths. Spring motors are not considered in this booklet.

B. TORQUE MOTORS are proven reliable, but are difficult to apply because of their limited speed/torque range. Where a relatively constant torque is required (such as in levelwinding), torque motors do well. Where the load varies, such as on monospiral reels, there are better drives available.

C. HYDRAULIC MOTOR DRIVES are strong, adjustable and messy. Gleason Reel avoids hydraulics, if possible.

D. SPECIALTY MOTOR DRIVES are available with or without controls for nearly all reeling applications.

Note: Due to the very wide range of reeling applications, it is best to define the exact need before assuming that any drive method is best. Each drive has its place and none has been proven universally "best".

3. Slip Rings

Slip rings are comprised of current conducting rings (one per conductor) and mated brush assemblies. Either the rings or the brushes are held steady, while the mating component is rotated. This allows current to pass through the sliding contact from the stationary to the rotary component. Slip rings are rated higher than the cable used to provide ample safety margins and to comply with the National Electric Code.

GLEASON HAS THE OPTION OF USING A VARIETY OF DRIVES. YOUR SPECIFIC APPLICATION WILL DEFINE THE DRIVE BEST SUITED TO YOUR NEEDS. MAY WE REVIEW YOUR APPLICATION AND PROVIDE YOU WITH A REEL DRIVE TAILORED TO THE REQUIREMENT?

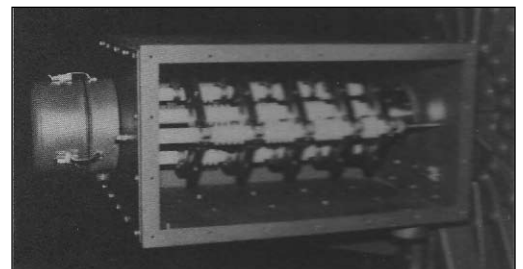

Level Winding Reels

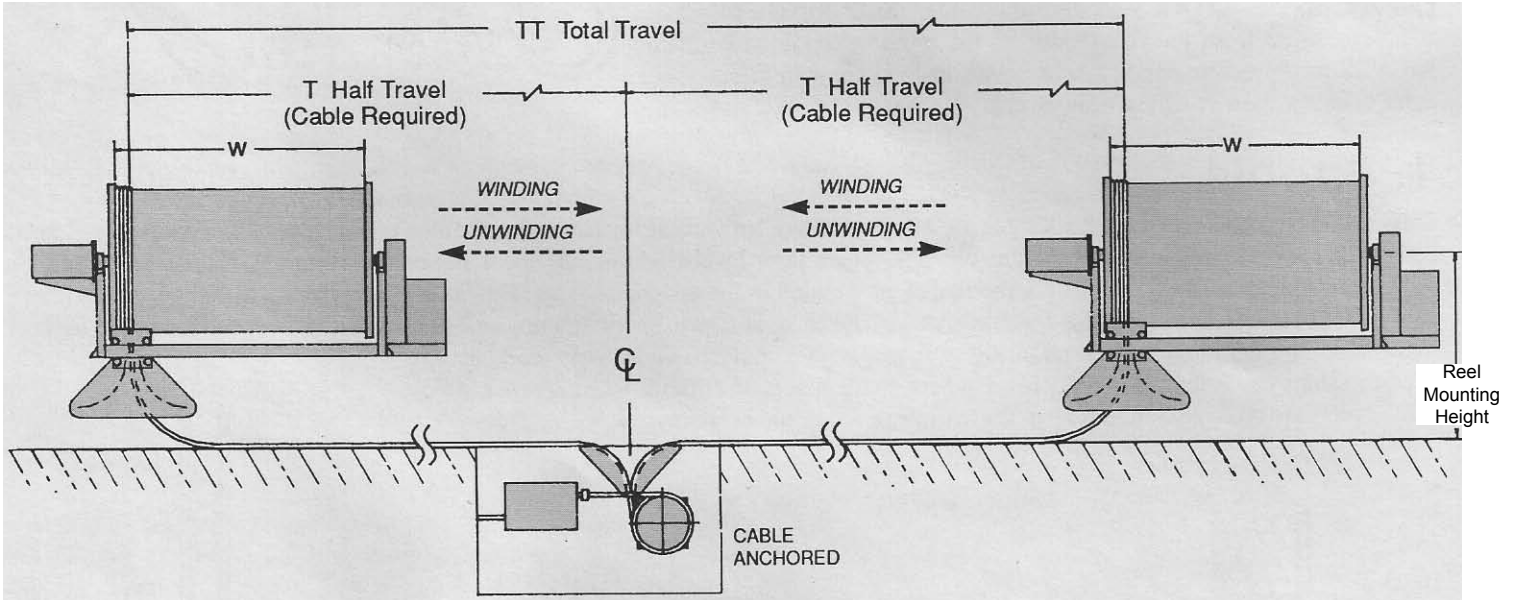

Sizing Your Reel

The EXAMPLE at right contains typical application data. The CHART below shows that data being *applied* using eight different total travel lengths (TT). The chart gives you an idea of the size of your reel. Calculations are made for AWG #2 cable and AWG #2/0 cable.

EXAMPLE Typical Application Specs

Cable:	5kv, Type SHD-GC
Total Travel:	(SEE CHART — Eight (8) examples)
Travel Speed:	150 fpm†
Acceleration:	1.0 fps ² †
Mounting Height:	Reel centerline is 20 ft. above the tray surface
Enclosures:	Weather-tight

The chart below assumes the above data.

Total Travel TT of Machine	FEET meters	750 229	1000 305	1250 381	1500 457	1750 533	2000 610	2250 686	2500 762
AWG #2									
Cable Required Feet* (T)		375	500	625	750	875	1000	1125	1250
Cable Required Meters* (T)		114	152	191	229	267	305	343	381
Cable Tension Required (lbs)		195	225	260	290	325	360	390	425
Max. Cable Tension** (lbs)		455	455	455	455	455	455	455	455
Drum Width Dim. "W" (in.)		72	96	96	120	144	144	168	192
Weight Cable (lbs)		1030	1350	1670	2000	2300	2600	2900	3200
Weight Reel (lbs)		4300	4700	4700	5200	5600	5600	5900	6300
Weight Total (lbs)		5330	6050	6370	7200	7900	8200	8800	9500
AWG #2/0									
Cable Required Feet* (T)		375	500	625	750	875	1000	1125	1250
Cable Required Meters* (T)		114	152	191	229	267	305	343	381
Cable Tension Required (lbs)		290	330	380	425	470	520	560	610
Max. Cable Tension** (lbs)		910	910	910	910	910	910	910	910
Drum Width Dim. "W" (in.)		72	96	120	144	168	168	192	216
Weight Cable (lbs)		1620	2100	2570	3070	3550	4030	4500	5000
Weight Reel (lbs)		4300	4700	5200	5600	5900	5900	6300	6700
Weight Total (lbs)		5920	6800	7770	8670	9450	9930	10800	11700

* Does not include cable required for connections and lead-ins. ** Tension recommended by cable manufacturers.
 † Has great influence on calculations — please be precise.

System Components

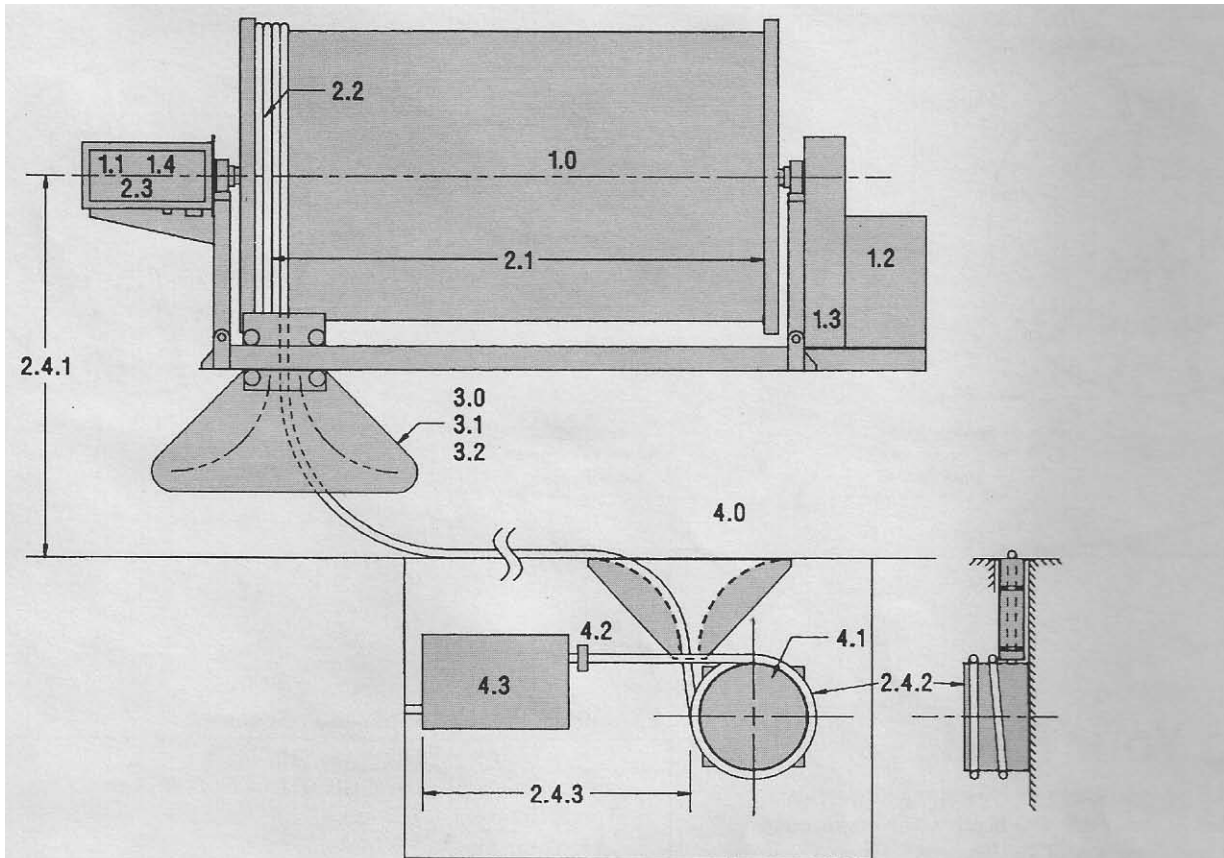

Application Check List

1.0 LEVELWIND REEL			
1.1 Slip Ring Assembly (<i>matched to cable</i>)	Poles _____	Volts _____	Amps _____
1.2 Reel Drive Assembly (<i>power supply</i>)	Phase _____	Volts _____	Hertz _____
1.3 Maximum Travel Limit Switch	<input type="checkbox"/> Yes	<input type="checkbox"/> No	
1.4 Enclosure Space Heater, 120V	<input type="checkbox"/> Yes	<input type="checkbox"/> No	
2.0 CABLE ASSEMBLY TOTAL			
2.1 Active Cable	= _____	FT	_____ m
2.2 Safety Wraps: _____ ft x 2 req'd*	= _____	FT	_____ m
2.3 Lead-In Cable @ 6 ft	= 6	FT	1.52 m
2.4 Hook-Up Cable			
2.4.1 From reel to ground level	= _____	FT	_____ m
2.4.2 From ground through anchor	= 20	FT	5.08 m
2.4.3 From anchor to terminal box	= _____	FT	_____ m
3.0 CABLE GUIDE AND CONTROLS			
3.1 Overtension Detector	<input type="checkbox"/> Yes	<input type="checkbox"/> No	
3.2 Undertension Detector	<input type="checkbox"/> Yes	<input type="checkbox"/> No	
4.0 TERMINATION COMPONENTS			
4.1 Cable Stress-Reliever	<input type="checkbox"/> Yes	<input type="checkbox"/> No	
4.2 Cable Clamp	<input type="checkbox"/> Yes	<input type="checkbox"/> No	
4.3 Cable Termination Box	<input type="checkbox"/> Yes	<input type="checkbox"/> No	

* Two safety wraps is typical. Length of each safety wrap will vary with spool size.

Monospiral Reels

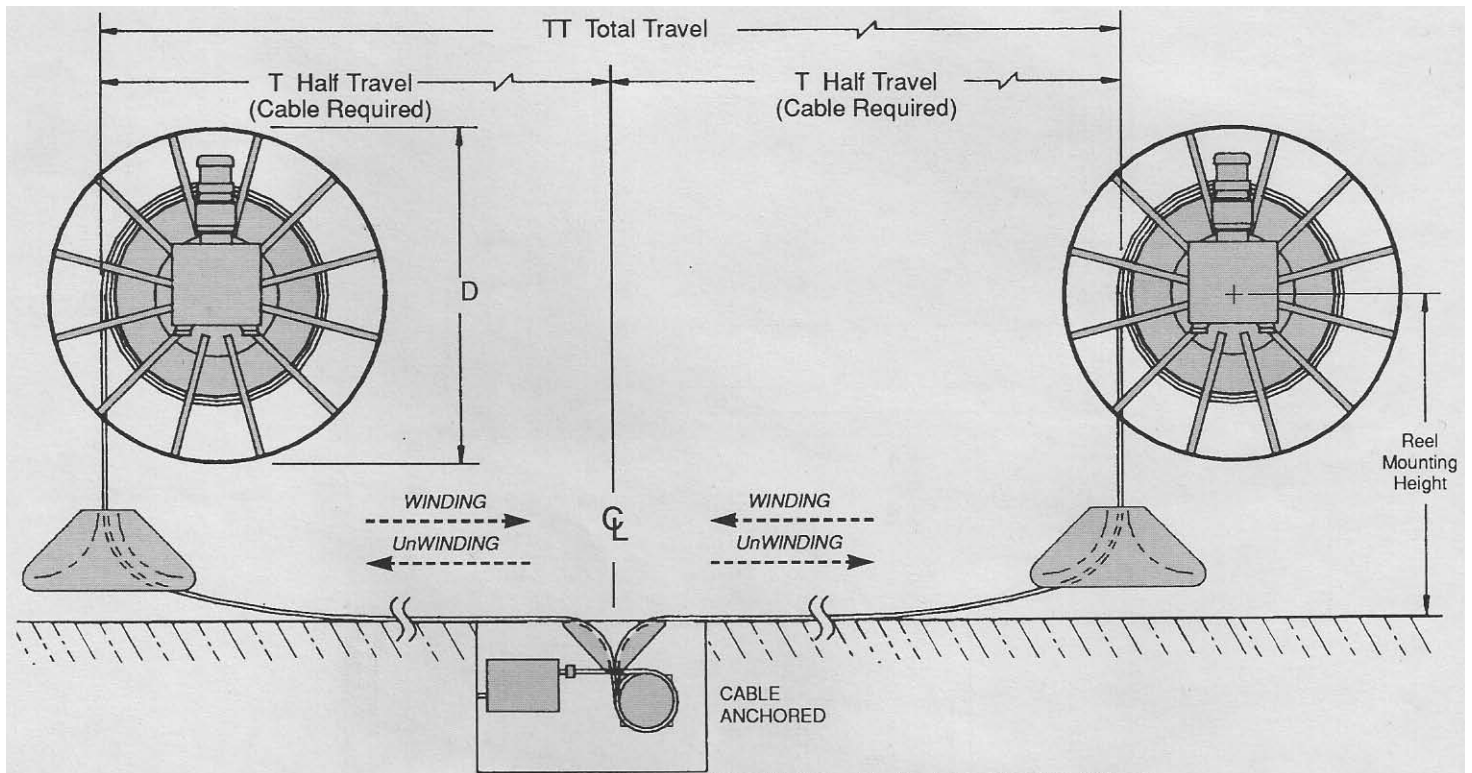

Sizing Your Reel

The EXAMPLE at right contains typical application data. The CHART below shows that data being *applied* using eight different total travel lengths (TT). The chart gives you an idea of the size of your reel. Calculations are made for AWG #2 cable and AWG #2/0 cable.

EXAMPLE Typical Application Specs

Cable:	5kv, Type SHD-GC
Total Travel:	(SEE CHART — Eight (8) examples)
Travel Speed:	150 fpm†
Acceleration:	1.0 fps ² †
Mounting Height:	Reel centerline is 20 ft. above the tray surface
Enclosures:	Weather-tight

The chart below assumes the above data.

Total Travel TT of Machine	FEET meters	500	600	700	800	900	1000	1250	1500
AWG #2									
Cable Required Feet* (T)		250	300	350	400	450	500	625	750
Cable Required Meters* (T)		76	91	107	122	137	152	191	229
Cable Tension Required (lbs)		195	225	260	290	325	360	390	425
Max. Cable Tension** (lbs)		455	455	455	455	455	455	455	455
Spool rpm Max/ Min		8/ 4	8/ 4	8/ 4	8/ 4	8/ 4	8/ 4	7/ 3	7/ 3
Spool Diameter Dim. "D" (in.)		128	136	142	150	154	158	180	192
Weight Cable (lbs)		720	850	970	1100	1220	1350	1670	2000
Weight Reel (lbs)		1200	1320	1380	1500	1600	1700	1900	2500
Weight Total (lbs)		1920	2170	2350	2600	2820	3050	3570	4500
AWG #2/0									
Cable Required Feet* (T)		250	300	350	400	450	500	625	750
Cable Required Meters* (T)		76	91	107	122	137	152	191	229
Cable Tension Required (lbs)		400	430	440	455	525	550	575	625
Max. Cable Tension** (lbs)		910	910	910	910	910	910	910	910
Spool rpm Max/ Min		8/ 4	8/ 4	7/ 3	7/ 3	7/ 3	7/ 3	7/ 3	6/ 3
Spool Diameter Dim. "D" (in.)		138	144	162	166	172	178	192	210
Weight Cable (lbs)		1100	1300	1520	1700	1900	2100	2570	3070
Weight Reel (lbs)		1450	1550	1750	1850	2000	2100	2600	3000
Weight Total (lbs)		2550	2850	3270	3550	3900	4200	5170	6070

* Does not include cable required for connections and lead-ins. ** Tension recommended by cable manufacturers.

† Has great influence on calculations — please be precise.

System Components

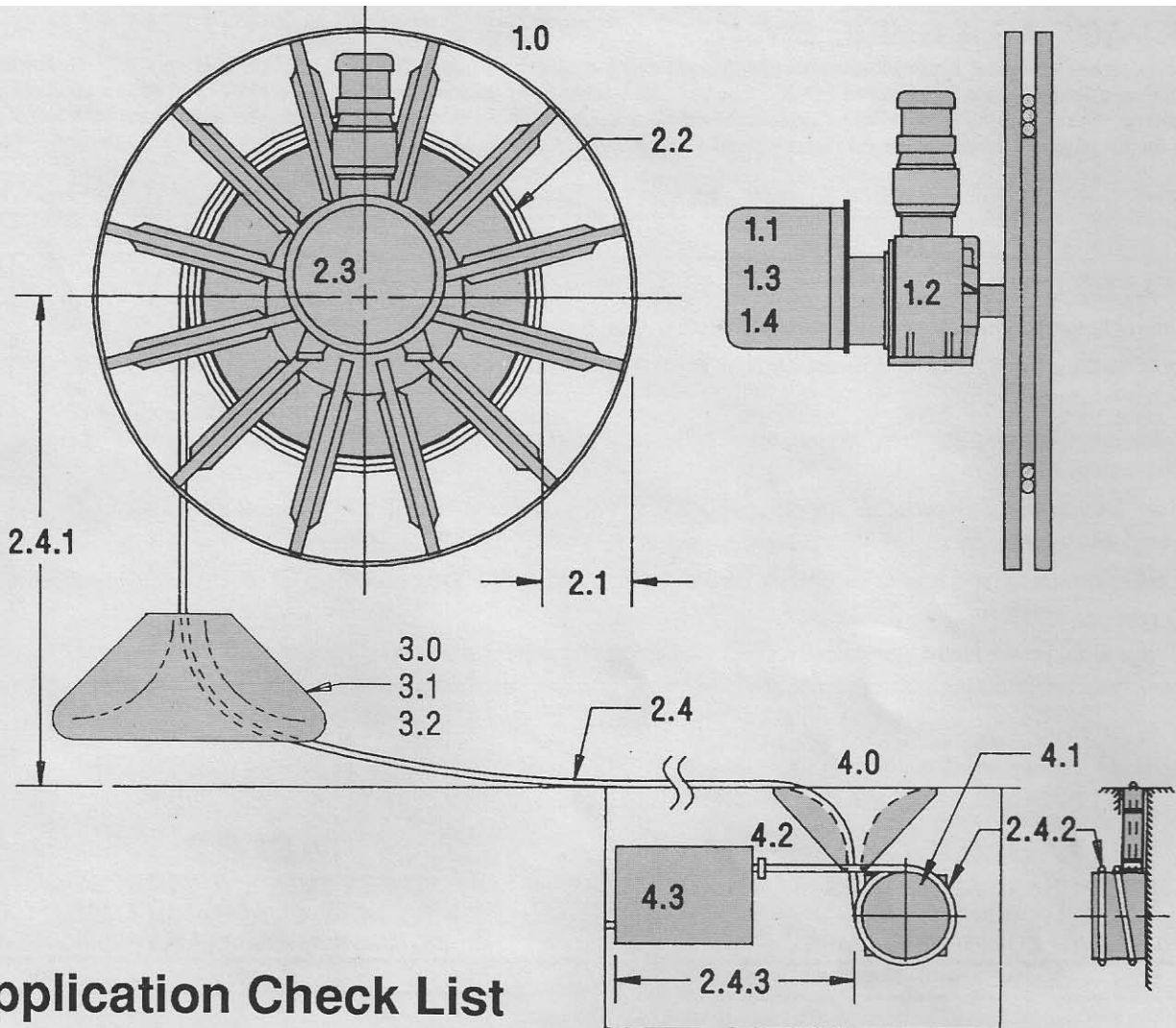

Application Check List

1.0 MONOSPIRAL REEL		Poles _____	Volts _____	Amps _____
1.1 Slip Ring Assembly (<i>matched to cable</i>)		Phase _____	Volts _____	Hertz _____
1.2 Reel Drive Assembly (<i>power supply</i>)		<input type="checkbox"/> Yes <input type="checkbox"/> No	<input type="checkbox"/> Yes <input type="checkbox"/> No	
1.3 Maximum Travel Limit Switch		<input type="checkbox"/> Yes <input type="checkbox"/> No	<input type="checkbox"/> Yes <input type="checkbox"/> No	
1.4 Enclosure Space Heater, 120V				
2.0 CABLE ASSEMBLY TOTAL	=	_____ FT	_____ m	
2.1 Active Cable	=	_____ FT	_____ m	
2.2 Safety Wraps: _____ ft x 2 req'd*	=	_____ FT	_____ m	
2.3 Lead-In Cable @ 6 ft	=	6 FT	1.52 m	
2.4 Hook-Up Cable				
2.4.1 From reel to ground level	=	_____ FT	_____ m	
2.4.2 From ground through anchor	=	20 FT	5.08 m	
2.4.3 From anchor to terminal box	=	_____ FT	_____ m	
3.0 CABLE GUIDE AND CONTROLS				
3.1 Overtension Detector		<input type="checkbox"/> Yes <input type="checkbox"/> No	<input type="checkbox"/> Yes <input type="checkbox"/> No	
3.2 Undertension Detector		<input type="checkbox"/> Yes <input type="checkbox"/> No	<input type="checkbox"/> Yes <input type="checkbox"/> No	
4.0 TERMINATION COMPONENTS				
4.1 Cable Stress-Reliever		<input type="checkbox"/> Yes <input type="checkbox"/> No	<input type="checkbox"/> Yes <input type="checkbox"/> No	* Two safety wraps is typical. Length of each safety wrap will vary with spool size.
4.2 Cable Clamp		<input type="checkbox"/> Yes <input type="checkbox"/> No	<input type="checkbox"/> Yes <input type="checkbox"/> No	
4.3 Cable Termination Box		<input type="checkbox"/> Yes <input type="checkbox"/> No	<input type="checkbox"/> Yes <input type="checkbox"/> No	

Selecting Cable

USE THIS PAGE AS A GUIDE ONLY...

Due to the great variety of electrical applications, types (and manufacturers) of controls, and available currents, it is very difficult for the reel manufacturer to select electrical cable for any specific requirement. Since the user, or specifying engineer is closest to all details involved in any particular requirement, the responsibility for selecting cable for a specific requirement must be left in their hands. To assist in the selection of cable, the tables shown on this page and the procedure below are offered as a guide only.

TO SELECT CABLE:

1. Determine total connected motor horsepower (HP).
2. Using **Table 1** for Alternating Current (AC) or **Table 2** for Direct current (DC), find the proper horsepower in the left hand column.
3. On the line showing proper horsepower, move to the right until reaching the column headed by the operating voltage to be used.
4. At this intersection the maximum ampere load is listed. For example, a 100 HP motor, operating at 460 volts three-phase current, draws 124 amperes.
5. Once maximum ampere load is known, we can determine the size of electric cable (AWG) required.
6. **CAUTION:**
Voltage drop, power factor corrections and derating frequently require an increase in size of conductors required.*

TABLE 1
THREE-PHASE AC MOTORS
(INDUCTION TYPE)
FULL LOAD CURRENT IN AMPS

HP	115V	230V	460V	575V	2300V
1/2	4	2	1	.8	
3/4	5.6	2.8	1.4	1.1	
1	7.2	3.6	1.8	1.4	
1 1/2	10.4	5.2	2.6	2.1	
2	13.6	6.8	3.4	2.7	
3		9.6	4.8	3.9	
5		15.2	7.6	6.1	
7 1/2		22	11	9	
10		28	14	11	
15		42	21	17	
20		54	27	22	
25		68	34	27	
30		80	40	32	
40		104	52	41	
50		130	65	52	
60		154	77	62	16
75		192	96	77	20
100		248	124	99	26
125		312	156	125	31
150		360	180	144	37
200		480	240	192	49

TABLE 2
DIRECT CURRENT MOTORS
FULL LOAD CURRENT IN AMPS
(MOTORS RUNNING AT BASE SPEED)

HP	120V	240V
1/4	2.9	1.5
1/3	3.6	1.5
1/2	5.2	2.6
3/4	7.4	3.7
1	9.4	4.7
1 1/2	13.2	6.6
2	17	8.5
3	25	12.2
5	40	20
7 1/2	58	29
10	76	38
15		55
20		72
25		89
30		106
40		140
50		173
60		206
75		255
100		341
125		425
150		506
200		675

For full-load currents of 208- and 200-volt motors, increase the corresponding 230-volt motor full-load current by 10 and 15 percent, respectively. These values of full-load current are for motors running at speeds usual for belted motors and motors with normal torque characteristics. Motors built for especially low speeds or high torques may require more running current, and multi-speed motors will vary full-load current according to speed, in which case the nameplate current rating should be used. REF., National Electric Code, 1990, Table 430-150.

REF., National Electric Code, 1990, Table 430-147.

*Consult the cable manufacturer for specific details

Cable Data

CABLE DIAMETERS AND NET WEIGHTS

The cables listed below are based on the current issue of the National Electric Code which should be referred to if additional details are needed. Diameters and weights will vary with manufacturers and we have selected generally conservative listings. Ampere ratings are based on 75°C (167°F) insulation for Type SO, W and G cable; 90°C (200°F) insulation for SHD-GC cable. Please advise us if other dimensions and weights are to be used so proper adjustments in reel calculations can be applied.

TYPE SO; 600 VOLTS

14 AWG			12 AWG			10 AWG					
NO. COND.	AMPS*	DIAMETER INCHES mm	WEIGHT LBS/FT KG/M	NO. COND.	AMPS*	DIAMETER INCHES mm	WEIGHT LBS/FT KG/M	NO. COND.	AMPS*	DIAMETER INCHES mm	WEIGHT LBS/FT KG/M
3	15.0	0.56/ 14.2	.186/ 0.2	3	20.0	0.64/ 16.3	.253/ 0.38	3	25.0	0.70/ 17.8	.311/ 0.46
4	12.0	0.61/ 15.5	.221/ 0.33	4	16.0	0.67/ 17.0	.297/ 0.44	4	20.0	0.75/ 19.1	.385/ 0.57
5	12.0	0.62/ 15.8	.288/ 0.43	5	16.0	0.73/ 18.5	.351/ 0.52	5	20.0	0.82/ 20.8	.461/ 0.69
6	12.0	0.74/ 18.8	.332/ 0.49	6	16.0	0.80/ 20.3	.409/ 0.61	6	20.0	0.88/ 22.4	.532/ 0.79
7		0.80/ 20.3	.362/ 0.54	7		0.86/ 21.8	.472/ 0.70	7		0.98/ 24.9	.649/ 0.97
8		0.85/ 21.6	.407/ 0.61	8		0.92/ 23.4	.519/ 0.77	8		1.05/ 26.7	.717/ 1.07
10		0.90/ 22.9	.477/ 0.71	10		1.02/ 25.9	.635/ 0.95	10		1.13/ 28.7	.838/ 1.25
12		0.93/ 23.6	.529/ 0.79	12		1.05/ 26.7	.706/ 1.05	12		1.16/ 29.5	.938/ 1.40
16		1.08/ 27.4	.723/ 1.08	16		1.16/ 29.5	.921/ 1.37	16		1.29/ 32.8	1.23/ 1.83
20		1.18/ 30.0	.865/ 1.29	20		1.29/ 32.8	1.10/ 1.64	20		1.46/ 37.1	1.55/ 2.31
24		1.29/ 32.8	1.01/ 1.50	24		1.45/ 36.8	1.35/ 2.01	24		1.60/ 40.6	1.81/ 2.69
30		1.40/ 35.6	1.25/ 1.86	30		1.53/ 38.9	1.60/ 2.38				
36		1.51/ 38.4	1.47/ 2.19								

TYPE W; 600 VOLTS

SIZE AWG	NO. OF CONDUCTORS	CAPACITY AMPERES*	DIAMETER IN.	mm	WEIGHT LBS/FT	KG/M
8	2	65	0.81	20.6	0.40	0.60
	3	57	0.90	22.9	0.56	0.83
	4	45	0.99	25.1	0.67	1.00
6	2	88	0.93	23.6	0.58	0.86
	3	77	1.01	25.7	0.74	1.10
	4	61	1.10	27.9	0.90	1.34
4	2	115	1.08	27.4	0.77	1.15
	3	101	1.17	29.7	1.05	1.56
	4	80	1.27	32.3	1.30	1.93
2	2	152	1.27	32.3	1.15	1.71
	3	133	1.34	34.0	1.39	2.07
	4	106	1.50	38.1	1.80	2.68
1	2	178	1.45	36.8	1.50	2.23
	3	156	1.50	38.1	1.78	2.65
	4	124	1.70	43.2	2.26	3.36
1/0	2	207	1.52	38.6	1.70	2.53
	3	181	1.65	41.9	2.23	3.32
	4	144	1.79	45.5	2.61	3.88
2/0	2	238	1.65	41.9	2.22	3.30
	3	208	1.75	44.5	2.59	3.85
	4	166	1.93	49.0	3.38	5.03
3/0	3	241	1.89	48.0	3.35	3.50
	4	192	2.07	52.6	3.85	5.73
	3	277	2.04	51.8	3.72	5.54
4/0	4	221	2.26	57.4	4.51	6.71
	3	310	2.39	60.7	4.05	6.03
	3	381	2.69	68.3	5.30	7.89
500	3	470	1.35	34.3	1.94	2.89

TYPE G; 600 VOLTS

SIZE AWG	NO. OF CONDUCTORS	CAPACITY AMPERES*	DIAMETER IN.	mm	WEIGHT LBS/FT	KG/M
8	3	57	0.91	23.1	0.60	0.89
6	3	77	1.01	25.7	0.76	1.13
4	3	101	1.17	29.7	1.08	1.61
2	3	133	1.34	34.0	1.53	2.28
1	3	156	1.51	38.4	1.89	2.81
1/0	3	181	1.65	41.9	2.32	3.45
2/0	3	208	1.75	44.5	2.77	4.12
3/0	3	241	1.89	48.0	3.34	4.97
4/0	3	277	2.04	51.8	4.12	6.13
250	3	310	2.39	60.7	4.62	6.88
350	3	381	2.69	68.3	6.01	8.94
500	3	470	3.04	77.2	8.45	12.58

TYPE SHD-GC; 5000 VOLTS

SIZE AWG	NO. OF CONDUCTORS	CAPACITY AMPERES*	DIAMETER IN.	mm	WEIGHT LBS/FT	KG/M
2	3	140	2.13	54.1	2.48	3.69
2/0	3	215	2.48	63.0	3.82	5.68
4/0	3	285	2.78	70.6	5.20	7.74

TYPE SHD-GC; 8000 VOLTS

SIZE AWG	NO. OF CONDUCTORS	CAPACITY AMPERES*	DIAMETER IN.	mm	WEIGHT LBS/FT	KG/M
2	3	165	2.13	54.1	2.48	3.69
2/0	3	245	2.48	63.0	3.82	5.68
4/0	3	285	2.78	70.6	5.20	7.74

TYPE SHD-GC; 15000 VOLTS

SIZE AWG	NO. OF CONDUCTORS	CAPACITY AMPERES*	DIAMETER IN.	mm	WEIGHT LBS/FT	KG/M
2	3	165	2.13	54.1	2.48	3.69
2/0	3	245	2.48	63.0	3.82	5.68
4/0	3	325	2.78	70.6	5.20	7.74

DERATING OF CABLE ON REELS

When full load currents are expected with cable layered on a reel, a correction factor is required. Single layer levelwind and monospiral reels should be derated to 0.76 to allow for thermal effects of adjacent coils. Derate second layer at 0.58; third layer at 0.47; fourth layer at 0.40; fifth layer at 0.36.

*Ampere figures from 1990 N.E.C.

Cable Use

Testing Reeling Cables

We are not a cable supplier, nor are we "cable experts." We do, however, manufacture a comprehensive line of cable management equipment which has given us considerable experience with cable.

When cable fails, the reel is often blamed. In many cases failure is actually due to misapplication of the reel - when the cable leaves safe storage off the reel, it is asked to perform twists and turns which no cable can survive. On the other hand, certain types of cable do last longer than others when equally applied. To that end, we have included some interesting test results.

TEST PARAMETERS

Testing was performed at a midwest test facility. Reels used were standard spring-driven cable reels. Cable was supplied by several vendors in 50 ft. lengths and stretched 40 ft. horizontally with a 6% sag. Pull was in and out horizontal at 150 fpm, continuous. Test rig was located out of doors and operated September through May. Inspections were made daily and cable was removed from testing at failure point - when conductors were exposed indicating loss of electrical continuity.

RESULTS

The chart at right shows the accumulated results of our testing. In an attempt to assign some relative "value" rating to the samples submitted, we estimated their cost per cycle. In our continuous use application it is clear that YOU GET WHAT YOU PAY FOR. Our "Super Import" sample was clearly superior to the others and we projected a useful life beyond the end of the test to be at least another 20%. Though it was the most expensive of the four, it withstood 27% more cycles than its closest competitor making its cost per cycle the lowest.

TESTING DATA BELOW IS TO BE USED AS A GENERAL GUIDE ONLY. IT IS BASED ON CATALOGED DATA AND EXPERIENCE.

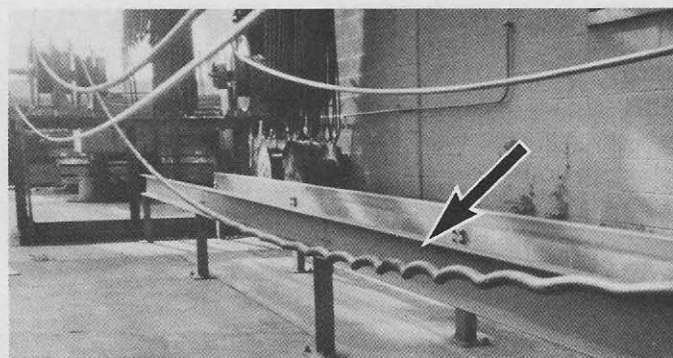

Standard "SO" cable nearing failure at our test facility.

	CABLE SAMPLE TYPE			
	Super Import	Reeling Import	Reeling USA	Generic "SO"
Weight	0.785 lbs/ft.	0.535 lbs/ft.	0.560 lbs/ft.	0.480 lbs/ft.
O.D.	1.300 in.	0.925 in.	1.020 in.	0.930 in.
AWG	14	14	14	14
Cond.	12	12	12	12
Cost*	\$6.09 /ft.	\$5.38 /ft.	\$6.00 /ft.	\$1.25 /ft.
Cycles	318,000 ¹	250,000 ²	150,000 ³	10,600 ⁴
\$/ Cycle	0.000019	0.000022	0.000040	0.000118
VALUE†	1.00	1.12	2.09	6.16

* Typical cost to OEM accounts through local cable distributors.

† Lowest cost/ cycle receives the value of 1.00. All other cost/ cycle figures are divided by the lowest cost/ cycle to obtain their "value" relative to the 1.00 standard. Ex., Generic "SO" cable costs 6.16 times more to operate.

- 1 Super Import cable showed wear on the jacket but no sign of failure at test's end when 265,000 cycles had been completed. We estimated at least 20% more life for the cable which would give it a minimum of 318,000 total cycles.
- 2 Reeling Import wore through jacket exposing conductors, but experienced no loss of electrical continuity.
- 3 Reeling USA lost 1st conductor.
- 4 Generic SO cable lost 1st conductor.

Typical Reeling Cables

TYPE	RATING	APPLICATION
"SO" or "W"	600 volt	General purpose neoprene jacketed cable with fine stranding for flexibility. Type "SO" for #10 or smaller; Type "W" for #8 or larger.
"G"	600 volt	Same as Type "W" but grounding conductor divided into three smaller wires rather than one large wire as in Type "W." Generally preferred for reeling service due to smaller diameter and symmetrical construction.
"G-GC"	600 volt	Same as Type "G" with one ground conductor insulated for ground check purposes.
"SHD-GC"	5KV 8KV 15KV	Same as Type "G-GC" but for high voltage service. Generally available in 5KV, 8KV or 15KV insulation.

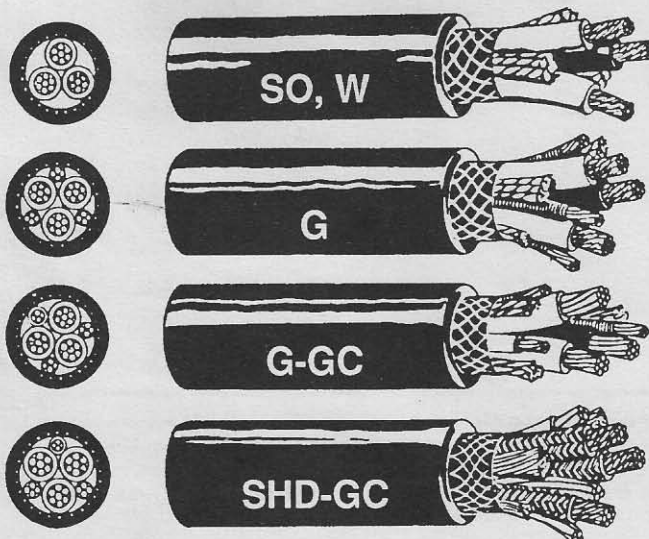

Bending Cable

WHENEVER YOU BEND A CABLE,
USE THE MAXIMUM RADIUS AVAILABLE.

In cable bending,
"BIG BENDS ARE BEST."

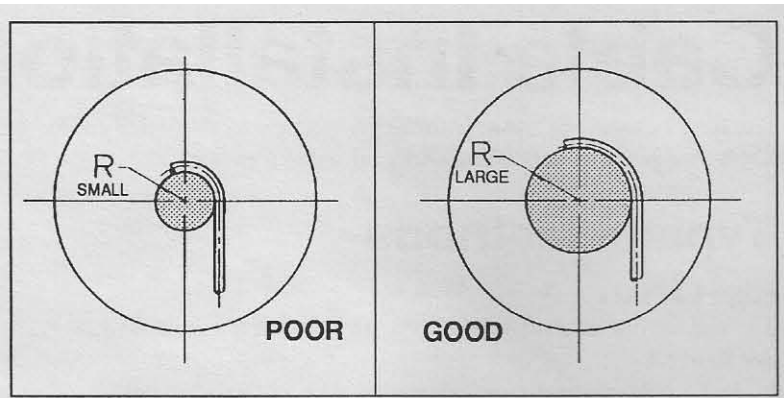

Bending Rules* Multiply cable O.D. by factor to find minimum bending radius

CABLE O.D. UP TO 1000 VOLT	ENTRY AND STRAIN RELIEF	REELING DEVICES	POWERTRAK SYSTEMS	FESTOON SYSTEMS
< 0.3 INCHES	3 x O.D.	5 x O.D.	4 x O.D.	3 x O.D.
< 0.5 INCHES	4 x O.D.	5 x O.D.	4 x O.D.	4 x O.D.
< 0.8 INCHES	5 x O.D.	5 x O.D.	5 x O.D.	5 x O.D.
> 0.8 INCHES	5 x O.D.	6 x O.D.	5 x O.D.	5 x O.D.
> 1,000 VOLT	10 x O.D.	12 x O.D.	10 x O.D.	10 x O.D.

*Specialty cables may allow different factor. Consult the cable manufacturer for details.

Sheaves

For large cables, the multiple roller-type guide is recommended. When individual sheaves are used, the points below are worth noting.

Round-Bottom Sheaves

With round-bottom sheaves, the only stable running position is dead center. Any deviation from the center position causes the cable to roll "downhill" into the bottom of the sheave, putting a twist into the cable. When the cable direction is reversed, the cable does not roll "uphill," and the twist remains and accumulates until the cable fails.

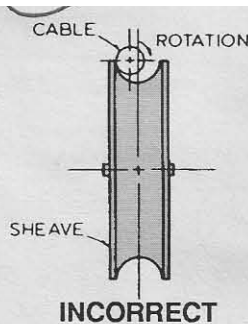

Flat-Bottom Sheaves

With flat-bottom sheaves, the cable rides on the bottom without rolling. The direction of rotation of the sheave in either direction does not twist the cable. The sheave width should be 15 to 20 percent wider than the cable.

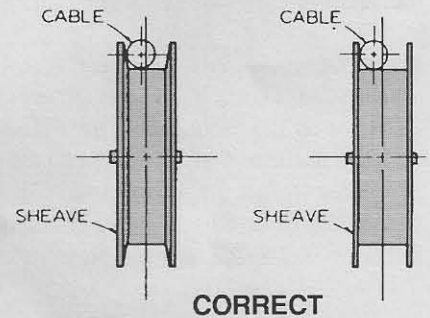

Cable Tensions

Line Pull Guide**

AWG	MAXIMUM RECOMMENDED PULLING FORCE FOR GOOD CABLE LIFE ON REELS								
	POUNDS	3 COND. 600V	Newtons	POUNDS	3 COND. 5kV	Newtons	POUNDS	3 COND. 8kV	Newtons
8	150	-----	670	—	-----	—	—	-----	—
6	240	-----	1060	—	-----	—	—	-----	—
4	380	-----	1690	285	-----	1270	285	-----	1270
2	605	-----	2690	455	-----	2020	455	-----	2020
0	720	-----	3210	720	-----	3210	720	-----	3210
00	910	-----	4050	910	-----	4050	910	-----	4050
000	1150	-----	5100	1150	-----	5100	1150	-----	5100
0000	1445	-----	6430	1445	-----	6430	1445	-----	6430
250 mcm	1710	-----	7600	1710	-----	7600	—	-----	—
500 mcm	3420	-----	15200	3420	-----	15200	—	-----	—

** Contact your cable manufacturer for specific details.

Cable Installation

The best methods of cable installation attempt to minimize cable twisting, avoid changed in direction and eliminate cable abrasion.

Typical Methods

FULL LAYOUT

The full layout method keeps cable twisting to a minimum. See Figure 2.

1) Jack up the transfer reel and unwind ALL of the cable onto the cable run, paying off of the top (fig. 1). The idea is to lay the cable out in a straight line, leaving both ends free.

2) Make cable connections at the working reel.

3) Move the working reel toward the free end while winding all cable onto the reel. This will allow cable twists to roll toward the free end and be relieved during this procedure.

DIRECT TRANSFER

If Full Layout cannot be used, direct transfer is a good alternative. This method is recommended when the working reel and/or cable runway are not accessible or when installing long runs of large diameter cable.

Try to accomplish the transfer in a straight line - avoid any change in direction. Passing cable around guides, including roller guides, is NOT recommended. See figures 3 & 4.

The transport-reel-to-working-reel transfer should be performed slowly and with a minimum of tension to avoid torsional influence on the cable during installation. The machine should be taken to the end of its travel and the anchor point released if detectable torsion (twist) is evident during installation. Twist should be removed and cable re-anchored. See "Removing Cable Twists" on the following page.

Cable Lay

POWER CABLES

Power cables are typically manufactured with a left hand conductor lay. This conductor lay has the natural effect of making the cable roll to the left. It is therefore important that the first turn of cable be installed on the drum or random would reel against the reels' left hand flange and angled correctly. See fig. 5. This allows the cable to layer on the drum correctly.*

CONTROL CABLES

Control cables are typically built with a left hand lay in North America. Imported control cables may be right hand lay.*

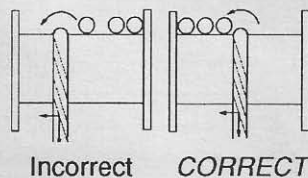

FIG 5

CHECK YOUR CABLES!

Please check with your cable manufacturer if there is any question regarding direction of cable lay.

*UL listed cables in N. America (power and control) are left hand lay on the outer lay, min.

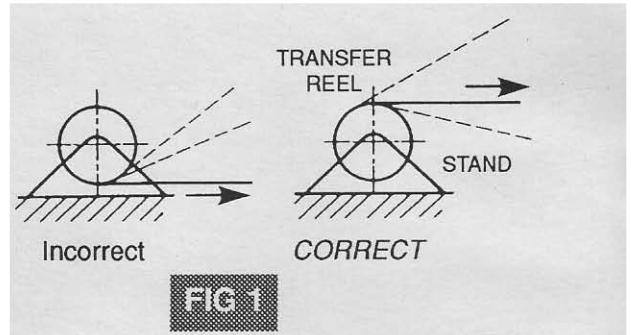

FIG 1

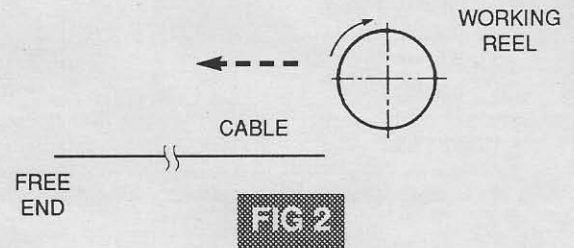

FIG 2

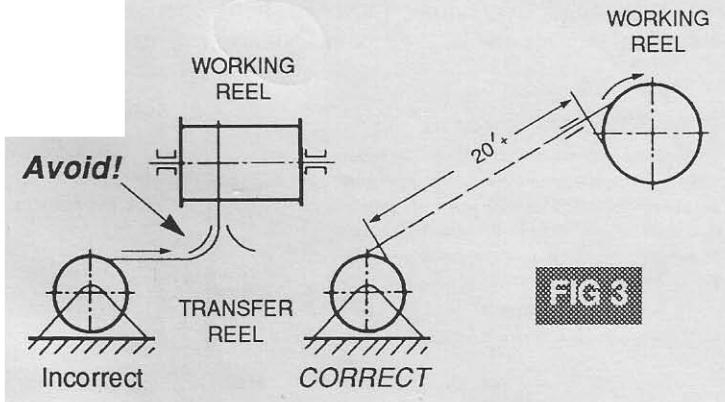

FIG 3

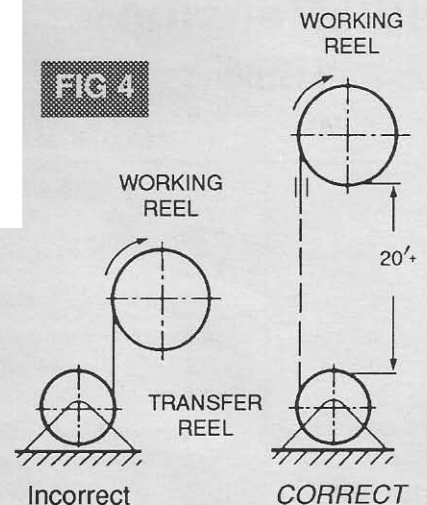

FIG 4

Removing Cable Twists

Twisted cable can lead to premature cable failure. Cable may be twisted at time of installation or it may become twisted as it is worked over time. Twisting should be removed to ensure maximum cable performance and service life.

If a twisting exists, it will be apparent. *(Please read "Cable Labeling" below.)* Unwind cable from reel until twist(s) are exposed, lying on the cable run. Disconnect cable from anchor point and remove all twists using one of the methods below. Reconnect cable at anchor point and rewind.

WAVE MOTION METHOD

A cylinder roller 6 to 8 inches in diameter is inserted underneath the cable behind the detected twist. Two people should then walk the roller and push the "wave" through the twist and toward the free end of the cable. This procedure should be repeated until the detected twist is removed. See figure 5.

SPIRAL METHOD

The spiral method can be carried out by one person to achieve the same effect as in the wave motion method. Enough cable should be provided at the cable's fixed end to make a spiral on either the left or right hand side depending on the direction of the twist. The spiral is then rolled to the free end of the cable thereby removing any twisting. This process may need to be repeated to remove all twists in the cable. The cable may then be re-anchored to resume operation. See figure 6.

Cable Labeling

Cable labeling machines print in a straight line. However, the cable may be twisting as it passes through the labeler. Therefore:

A TWIST IN CABLE JACKET LABELING IS NOT AN ABSOLUTE INDICATION OF ACTUAL CABLE TWIST.

See figure 7.

Lubrication

To assist in the movement of the cable over guide rollers, sheaves, etc., a dry lubricant or silicone-based grease may be used. This type of lubricant is resistant to grit and dust adhering to the lubricated surface.

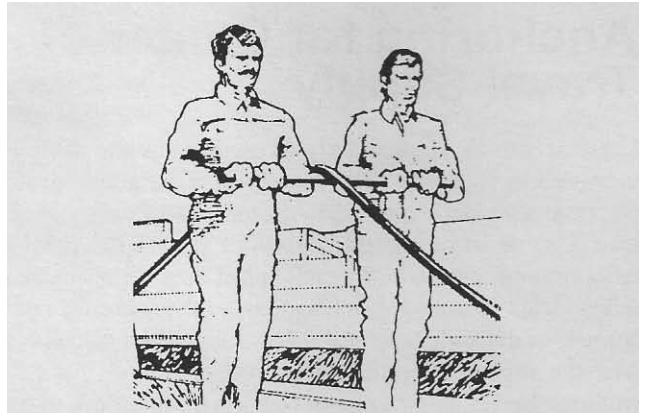

FIG 5



FIG 6



FIG 7

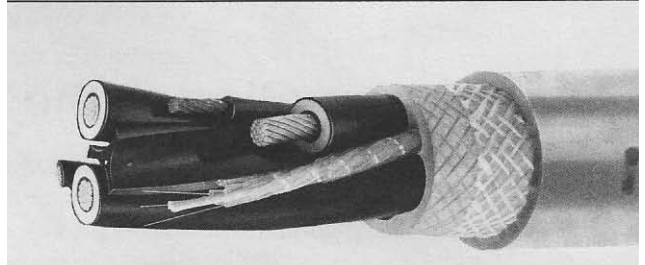

Cable Anchoring

Anchoring for Center of Travel Supply

Cable anchoring is commonly located below the cable run as indicated in figure 1. The system may be above ground or placed in a pit, depending upon the location of the cable run. At least 2 cable turns should be wound around the fixed stress relief drum to ensure sufficient contact area for adequate stress relief. This is the most difficult type of anchoring operation because of dynamic load peaks that occur as the machine passes over the anchoring point and the reel is stopped by the cable while it changes its direction of rotation from retrieve to payout.

Reel Mounting

By mounting the reel high and eliminating the guide (when possible) a monospiral reel will slow its rpm due to its increased diameter and allow safe center point crossing. This "pendulum" effect should be discussed.

Travel Speed Reduction

This system can be incorporated with the reel drive design. It reduces travel speed before reaching the center point, and then re-accelerates once the center point has been passed and the reel's direction of rotation has been reversed.

Center Point Location

It can often be determined during the design phase of an installation which portions of the travel distance will be most frequently traversed. A simple relocation of the anchor point to an off-center position may be all that is required to minimize cable flexing and the risk of excessive cable wear.

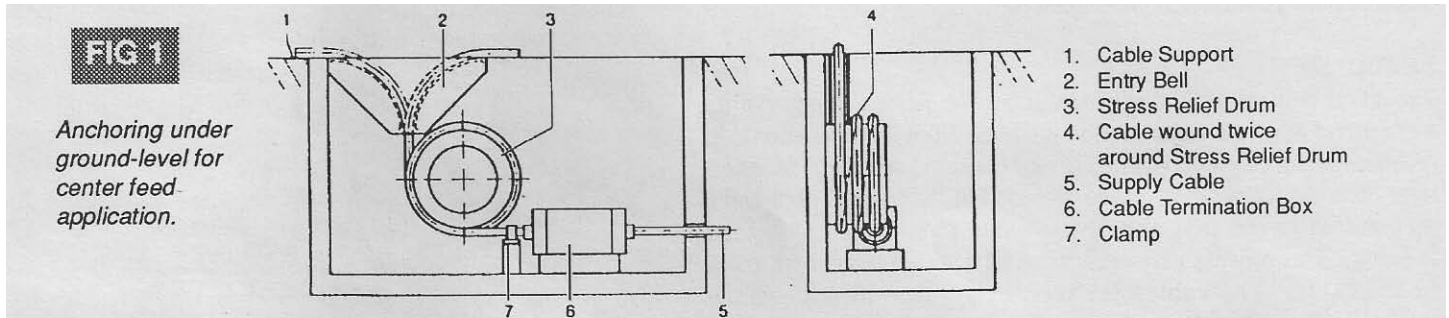

Anchoring for End fed Supply

An end-fed supply anchor is not usually subjected to the arduous dynamic stresses associated with center fed anchors. However, even with this type of anchoring, a stress relief drum is recommended. The system is maintenance free,

absorbs dynamic stresses and permits easy removal and replacement of the cable. This type of anchor can be installed above ground level as shown in figure 2, or below ground level to provide additional protection against accidental damage.

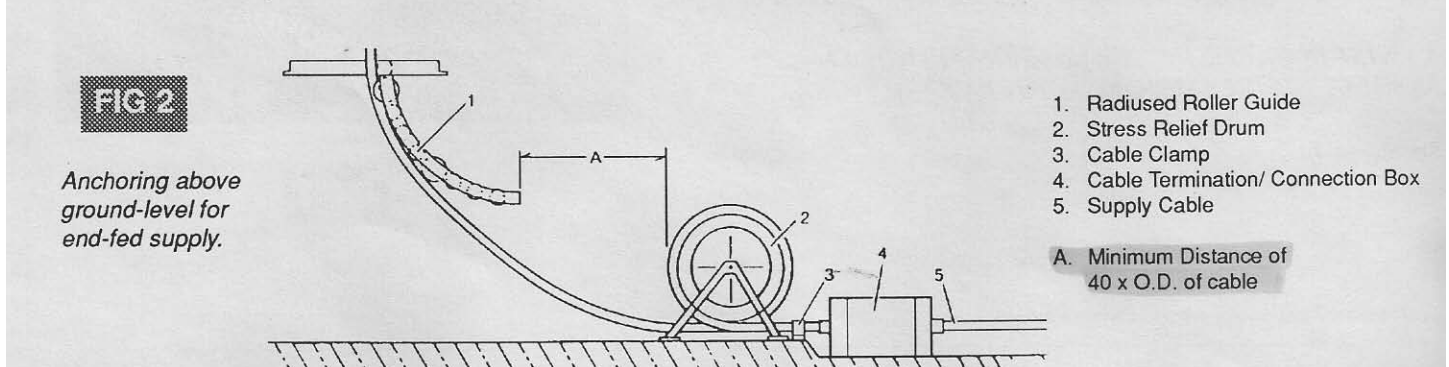

Cable Termination at the Anchor Point

A mining or marine type plug or coupler may be used rather than a cable termination connection box in installations which are prone to cable damage. This arrangement allows simple and fast removal for repair purposes. For installations below ground level, the system may be subjected to groundwater and/or tidal influences. Obtain

information from the plug/coupler manufacturer regarding suitable selection. The correct sealing and filling compounds should be used to ensure reliable performance under these conditions. Check local conditions and practices for specific needs.

Anchoring with a Kellems® Grip

When cable anchoring methods such as Kellems® Grips (Cable Stockings) are utilized, a recommended length of coverage over the cable is 20 x cable O.D. This will aid in spreading the dynamic stresses over a sufficient jacket surface area to inhibit cable damage. The distance from the end of the anchoring device to the end of machine travel should be at least 40 x cable O.D. If frequent dynamic stresses near the anchor point are anticipated, and a stress bearing disc cannot be used, a spring may be used. Is should be rated near the maximum safe continuous

working tension of the cable, and be installed between the clamping device and the fixed anchor. End-fed anchoring system designs can also be applied to other cable handling applications, such as vertical reel anchoring.

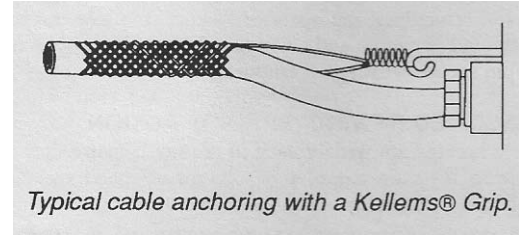

Typical cable anchoring with a Kellems® Grip.

Cable Guides FOR CHANGES IN DIRECTION

When designing a cable guiding system, allow sufficient distance between any direction changes. The recommended distance should be at least 20 x cable O.D. (longer for speeds greater than 300 fpm). Implementing this design will extend cable life by giving the cable's "memory" an

opportunity to shed torsion before making another change in direction. All "S" type directional changes and alternate place changes should be avoided. This unduly stresses the conductor assembly, especially at higher travel speeds. Pages 2, 4 and 6 of this catalog show typical changes in direction requiring a guide.

Roller Guides

The radiused roller guide consists of multiple rollers mounted in a housing designed for uni-directional or bi-directional cable payout. Because the individual rollers move independently of each other, torsion buildup in cable is reduced significantly as compared to large diameter single rollers.

This cutaway of a "two-way" roller guide shows multiple rollers plus the pendulum mounted rollers used to activate over/under tension switches.

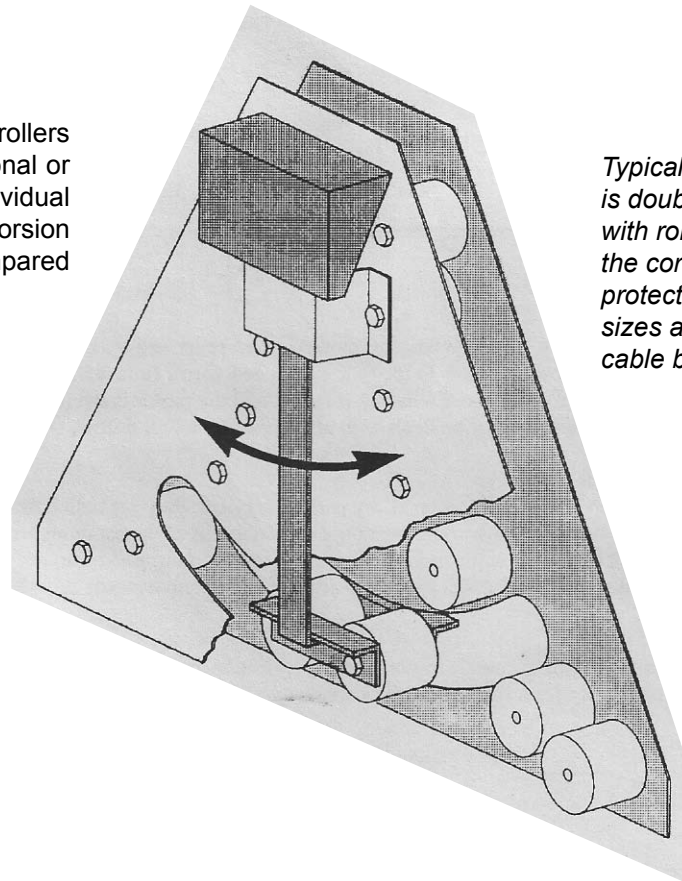

Typical construction is double steel plates with rollers mounted in the correct arc to best protect cable. Various sizes are used to suit cable bend radii.

Overtension and Undertension Protection

It is highly recommended that cable guiding systems include both undertension and overtension protection systems. Even a short exposure to overtension caused by mechanical failure or accidents can render a cable inoperable due to permanent conductor deformation. Conversely, undertension protection is desirable to ensure

that excessive cable cannot free spool from the reel and sustain damage. This protection is particularly important for long-lift cable reels. All overtension protection devices should be set above the maximum continuous safe working tension of the cable and adjusted to suit the specific application.

Reeling Functions - By Type

A. WINCH ACTION SUCH AS A PENDANT STATION REEL Winch action is simple: a reversing electric motor raises and lowers a payload. It is fully ON or fully OFF and the motor is NOT required to tolerate variations in spool rpm speed as the spool empties/fills - the motor runs at constant speed and spool rpm is a function of pulling diameter.

B. ASSISTED REWIND ACTION SUCH AS A HOSE REEL ON A FUEL DELIVERY TRUCK An electric motor running one direction assists in the rewind function only. An operator disengages the clutch and pulls the cable or hose off of the reel. For rewinding, the operator "walks" the free end back to the reel, re-engages the clutch, starts the motor and controls the rewind process. Assisted rewind is simple and economical but only semi automatic. It is fully ON or fully OFF and the motor is NOT required to tolerate variations in spool rpm speed as the spool empties/fills.

C. UNASSISTED REWIND (SPRING) ACTION Mechanical springs are widely used in reeling because they are fully automatic and simple: they are always "on"; they do not require an external power source; they are completely tolerant of speed variations and they are inexpensive. However, in this discussion we are dealing with long lengths of heavy cables for which mechanical springs are impractical. Now what...

ELECTRIC MOTORS CAN BE MADE TO FUNCTION LIKE MECHANICAL SPRINGS IN ORDER TO BENEFIT FROM THEIR BIGGEST ADVANTAGE - THAT OF BEING FULLY AUTOMATIC! The following is an explanation of how a non-reversing electric motor can drive the reel automatically, simply and economically without the need for special controls or human attention. The goals: Simplicity, Reliability & Economy.

Motor Drives Providing "Spring" Action

THE REELING CYCLE - "T" In **Figure 1**, the motor must allow the machine to literally pull cable off of the reel (unwind) as it moves from CL; the motor is overhauled, i.e. pulled *backward*, and acts as a "drag brake" *only*, to maintain tautness. In **Figure 2**, when the machine moves toward CL, the reel must rewind the cable back onto the spool; this is the DRIVE function for the motor - it is turning *in the same direction* as the spool.

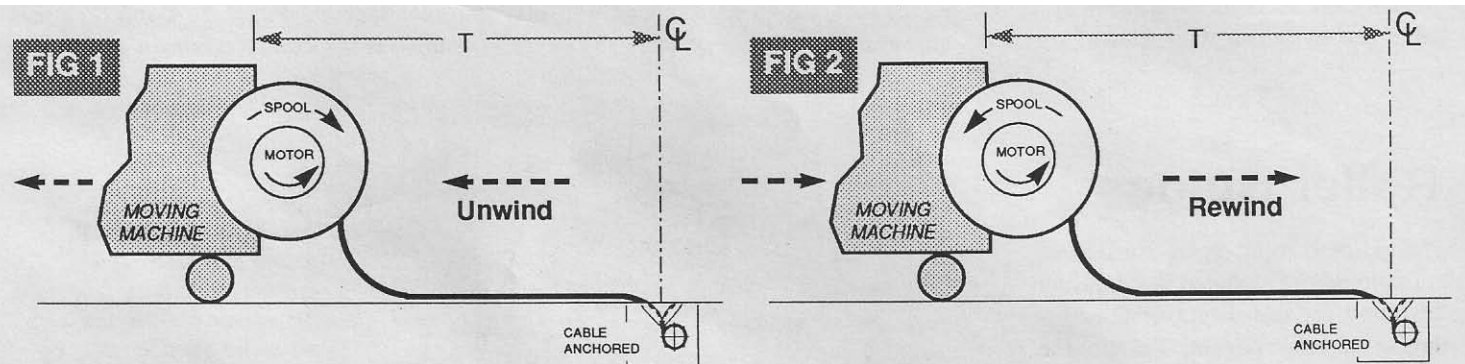

THE PROBLEM

The electric motor driving the reel is simple when the motor is non-reversing and energized whenever the machine moves — this simulates the simplicity of a spring. Problems develop when 1) the *machine* speed varies (unused motor current converts to heat)*; 2) the machine stops (ALL motor current converts to heat); or 3) cable is unwinding (FIG. 1) and the motor is overhauled, i.e., pulled *backward* (ALL motor current converts to heat). **HEAT IS THE PROBLEM** and it must be dealt with effectively or it will destroy the motor.

1. TORQUE MOTOR DRIVES

Drives are available to tolerate the conditions imposed by reeling service; they are called torque motor drives. Torque motor drives are oversized to allow a 100% locked rotor condition (stall) without burning out. Such drives do not require reversing controls since they allow the slippage required in reeling. They can be energized full-time, further eliminating controls. *In application, the torque motor drive is a big, weak, inefficient drive, but the simplest, most reliable drive for the demands of reeling service.* The torque motor drive has serious application limitations at higher speeds.

2. HYDRAULIC DRIVE

Hydraulic drive systems employ standard electric motors driving hydraulic motors for a wide range of high-speed and high-power applications. Generally used for the most demanding applications, hydraulic drives are recognized as the most vulnerable to abuse and have a history of high maintenance.

DRIVES PICTURED
IN RELATIVE SCALE

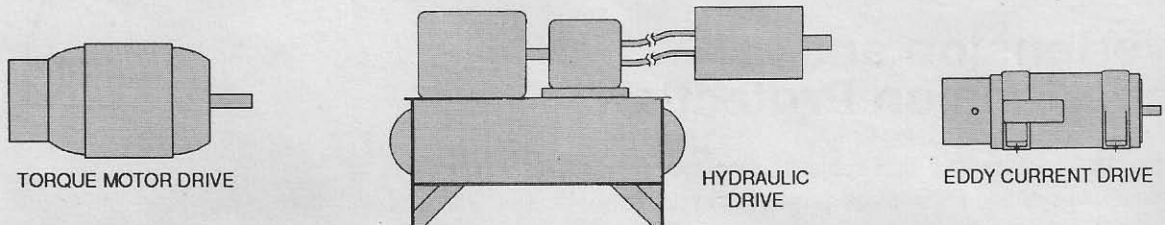

3. OTHER REEL DRIVE OPTIONS

Other reel drives utilize a standard motor PLUS a coupling of some type (eddy current, permanent magnet, hydraulic, slip-clutch, etc.) which allows a non-reversing motor to run at full current load while the coupling tolerates speed variations (i.e. dissipates the heat) typical in a reeling application.

* Rate of heat generation is 745.7 watts per hp or about equal to a hair dryer.

Reel Drives - Traditional Solutions

Torque Motor Drives

Torque motor drives are very small motors in very large frames and are designed to tolerate the heat generated by variations in motor speed without the use of controls. Torque motors can be reverse wound under full current load without harm - the large frame acts as a "heat sink." Torque motor drives can act like an electrical spring and provide the infinite turns required when reeling long cables. Torque motors are very reliable and simple but they also very large and limited in practical application possibilities.

Hydraulic Motor Drives

Hydraulic motors are driven by a pump with various valves compensating for speed variations. Hydraulic motor drives provide high torque but tend to be messy. The high torque and wide speed range provide expanded application capabilities.



Standard Motors with Special Features

Various magnetic and mechanical drives have been developed for reeling service. Gleason Reel uses an adjustable electrical/magnetic eddy current drive comprised of commercially available components. This proven drive is available in sizes to suit most reeling needs and provides the advantage of optional electronic controls, when required. The result is a reliable reel drive which is easy to apply, easy to maintain and easy to use and adjust. In short, it's "user friendly" and can be applied to nearly all known reeling applications. **Gleason Reel will be happy to assist in determining the best drive for your application.**

Comparing Drives

In order to compare the relative merits of typical reel drives, we have chosen a common requirement (2-1/2 hp) on a motor driven reel. Below we compare the size, availability, simplicity, adjustability, efficiency and cost for such a reel drive. Keep in mind that the resulting figures are merely typical and intended to compare the drives on an "even playing field." Variations in application will change the results.

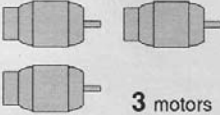
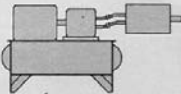
CHART BELOW ASSUMES:
 Approx. 2-1/2 hp Output @ 250 rpm
 All drives 460/3/60

	TORQUE MOTOR DRIVE	HYDRAULIC DRIVE	EDDY CURRENT DRIVE
A. Units Required for 2-1/2 hp <i>DRIVES SHOWN IN RELATIVE SCALE</i>	 3 motors	 1 unit	 1 unit
B. Space Requirement	Bulky	Can Remote Locate	Compact
C. Weight (lbs)	1050	700	250
D. Efficiency (%)	13.2	59.5	58.1
Watts In @	14,100	3,266	3,110
Watts Out @	1,865	1,940	1,813
E. Usable Torque (lbs/ft)	52.5	54.4	51.0
F. Inertia (lbs/ft)	40.0	28.5	90.6
G. Controls Required?	NO	YES	YES
H. Range of Torque Adjustment (%)	-15	-100	-100
I. Normal Drive Delivery (weeks) [†]	8 - 12	8 - 12	8 - 12
J. Relative Drive Cost*	100	58	43

* Estimated relative user cost of basic drive only. From vendors Feb., 1991.
[†] Does not consider stocking of finished drives.



Gleason Reel Corp.
 600 South Clark St. • P.O. Box 26
 Mayville, WI 53050
 Phone: 920-387-4120
 Fax: 920-387-4189
 www.hubbell-gleason.com